

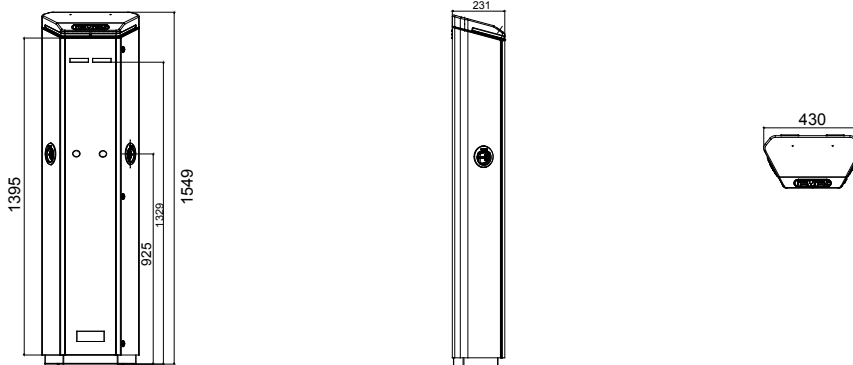

The floor-standing I-ON charging stations are the JOINON solutions for public and semi-public access, designed for charging electric vehicles and to withstand any wear including impacts, stress, vandalism and atmospheric agents. They are the first and only on the market able to guarantee the IP55 level of protection. The special hexagonal design allows the units to be adapted into any urban context and parking configuration, with a targeted focus on the User Experience for the Driver. They are available with standard JoinOn graphics, which may be customised on request.

<b>INPUT</b>	-	Socket/Connector Nr. (Type)	2 (Type 2 vandal-proof socket, with shutters) + 2(Type F)
Terminal blocks	5 x 35 mm <sup>2</sup>	Charging activation	Locally managed, via RFID
Rated current	64 A	Human Interface	LED RGB and TFT Display
Total power	44 Kilowatt	Connectivity	No
<b>OUTPUT</b>	-	<b>MECHANICAL FACTS</b>	-
Rated voltage	400 V	Mounting and installation	Floor mounting
Current supplied (max)	32 A per socket (10 A for Type F)	Colour	Grey, Headboard RAL 7011
Power max.	22 kW per socket (2,3 kW for type F)	Material	Steel sheet
Thermal-magnetic protection	40A - 4P - D Curve	External treatments	Anti-corrosion and anti-graffiti
Type of residual current protection	40 A - 4P - Type B	IP degree	IP54
Power meter	Yes (Type MID)	Mechanical resistance	IK10
DC Leakage check	Not needed	Operating temperature	-25 +50 °C
(Auto)restart electrical protections	No	Customizations	Yes (front)

### DIMENSIONAL



### TECHNICAL SYMBOLOGY

**IP**

**IK**

IP54

IK10

### STANDARDS/APPROVALS

